

STENSBALLE 

Snow blade type FS 1300 L

Model 2000 - 13.01.2003

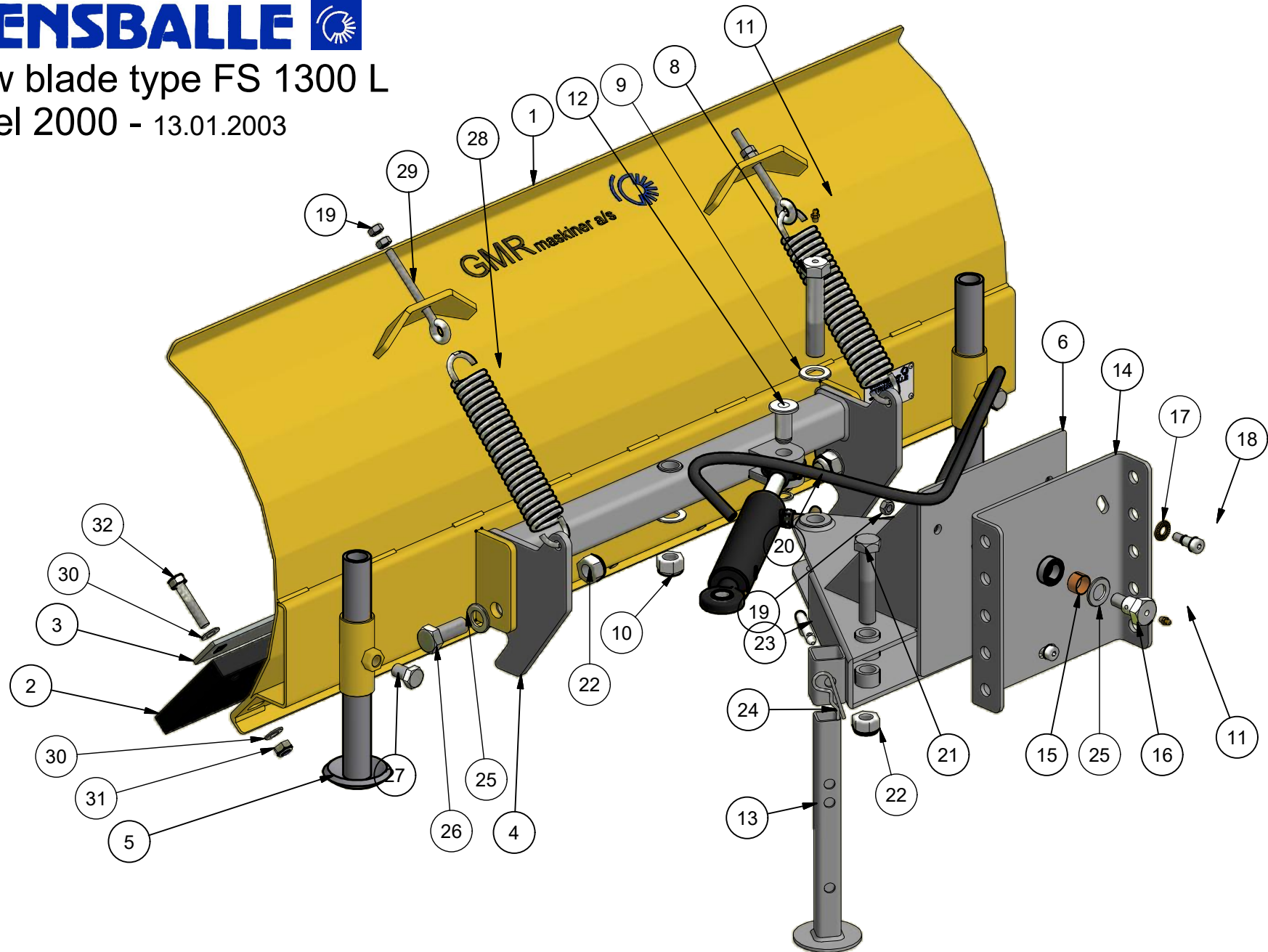

STENSBALLE

Snow blade type FS 1300 L

Model 2000

drawing lk 13-01-2003

<i>Pos.</i>	<i>Description</i>	<i>Ps.</i>	<i>Number</i>	<i>Remarks</i>
1	Snow blade	1	84-010-100	
2	Rubber shear	1	80-213-006	
3	Holder for shear	1	84-010-111	
4	Main bracket	1	88-008-020	
5	Skids	2	84-010-500	
6	Yoke	1	89-311-150	
7	Cylinder	1	01-440-106	
8	Pivot bolt	1	80-213-001	
9	Washer	3	36-300-022	
10	Lock nut	1	31-101-022	
11	Greaser	2	57-000-008	
12	Pinbolt for cylinder	1	88-008-025	
13	Support leg	1	84-010-600	
14	In between frame	1	89-311-160	
15	Bronzw bushing	1	54-622-015	
16	Pivot bolt	1	53-200-002	
17	Contact washer	3	53-200-012	
18	Bolt	3	32-410-016	
19	Nut	7	31-001-010	
20	Lock ring	1	20-101-020	
21	Bolt	1	28-120-100	
22	Lock nut	3	31-101-020	
23	Pinbolt	1	13-000-004	
24	Hair pin	1	38-204-075	
25	Washer	4	36-300-020	
26	Set screw	2	29-120-050	
27	Set screw	2	29-116-025	
28	Spring	2	61-386-532	
29	Eyebolt	2	30-910-100	
30	Washer	18	36-300-012	
31	Lock nut	9	31-101-012	
32	Bolt	9	28-112-060	